

# SÜMBÜL

JACINTH



# SÜMBÜL

## JACINTH

İçten Motorlu Promosyon Dolabı / Plug-In Promotion Cabinet



İç montaj soğutma grubu ile paketlenmiş şarküteri ürünlerinin teşhiri için tasarlanmış olan Sümbül modeli; ürünlerin görünürlüğünü maksimum kılan tasarımı, zengin renk seçenekleri, self servis imkânı ve kolay hareket kabiliyeti ile süpermarketler ve hipermarketler için vazgeçilmez bir tercihtir.

The Jacinth model, which has been designed for displaying packed dairy products with its internally assembled cooling group, is the ideal selection for supermarkets and hipermarkets with its design which is maximizing product visibility, rich colour options, self service opportunity, with its ease of movement capability.

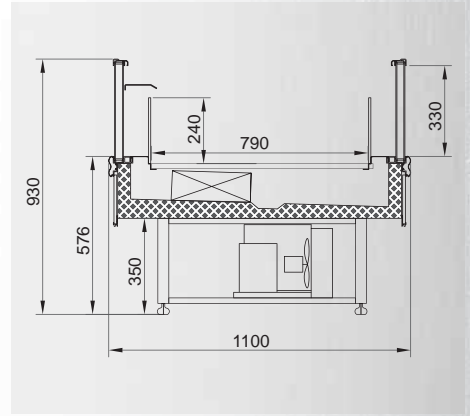

Sümbül / Jacinth

Uzunluk / Length mm	1250	1500
Teşhir Alanı / Display Area m <sup>2</sup>	0,99	1,19



## TEKNİK DETAYLAR / TECHNICAL DETAILS

SOĞUTMA TİPİ COOLING TYPE	ÇALIŞMA SICAKLIĞI OPERATING TEMPERATURES	DEFROST TİPİ DEFROST TYPE	ÇALIŞMA VOLTAJI OPERATING VOLTAGE	ORTAM KOŞULLARI AMBIENT CONDITIONS
Fanlı With Fan	+2 / +4 °C	Off Cycle	220V	25 °C / %60 rH

- Çağlayan Soğutma önceden haber vermeksizin teknik özellikler ve aksesuarları değiştirme hakkını saklı tutar.
- Çağlayan Refrigeration reserves the right to change any technical details and accessories without previous notice.

# EXCELLENCE HARMONY OF FUNCTIONALITY AND ELEGANCE

**ÇAĞLAYAN**<sup>®</sup>  
REFRIGERATION

[www.caglayansogutma.com.tr](http://www.caglayansogutma.com.tr) | [www.caglayanrefrigeration.com](http://www.caglayanrefrigeration.com)

